

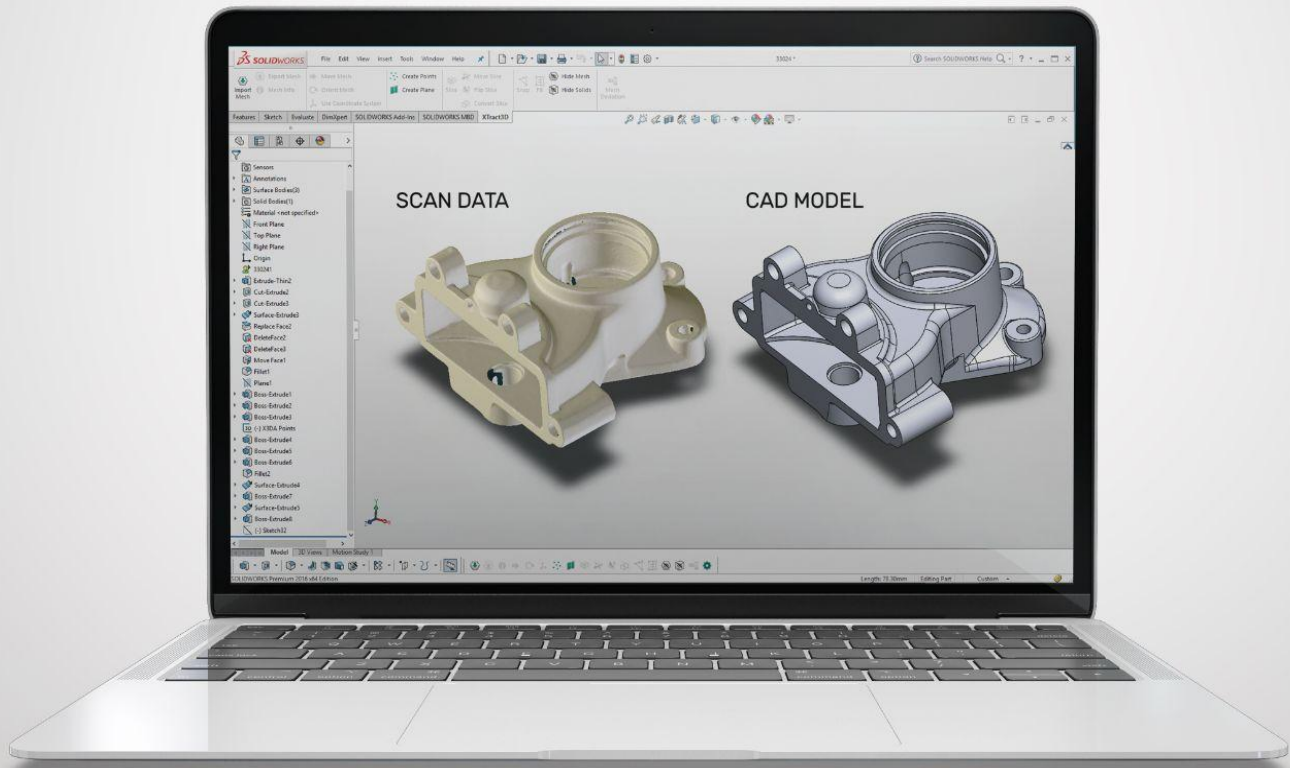

XTRACT3D

USER MANUAL 1.0



Copyright © by Polyga Inc. All rights reserved.

Reproduction in whole or in part in any way without written permission from Polyga is strictly prohibited. This manual is furnished for informational use only, and is subject to change without notice. Polyga assumes no responsibility or liability for any errors or inaccuracies that may appear in this document.

For additional information please contact support@polyga.com

Table of Contents

Table of Contents	2
Introduction	3
Intended Audience	3
System Requirements	3
Quick Start	4
Xtract3D Fundamentals	7
Concepts	7
File Import/Export	7
Import	7
Export Mesh	8
Mesh Info	8
Edit Mesh	9
Mesh Processing	10
Move Mesh	11
Orient Mesh	11
Align Mesh to Solids	12
Create Entity	13
Create Plane	14
Cross Section Entity	15
Drafting and Modeling	17
Slice	17
Snap	20
Fit	20
Project	21
Point Cloud Data Processing	21
Hide All Meshes	21
Hide Solids	22
Clip PCD Sphere	22
Clip PCD Cube	22
Mesh Deviation	24
Settings	24
License	25

Introduction

XTract3D is a reverse engineering toolbar that works natively inside SOLIDWORKS. There is no need to create CAD models from scratch. XTract3D gives you powerful slicing, fitting, and snapping tools to create parametric CAD simply by tracing right on top of 2D cross sections of 3D scan data (Scan-to-CAD).

Intended Audience

This document is for new Xtract3D users. In this document, the concepts and design process for reverse engineering will be introduced in a high-level approach. Online video tutorials contain a comprehensive set of tutorials that provide step-by-step instructions on the features of Xtract3D including many samples.

Online tutorials can be accessed here: [Xtract3D Video Tutorials](#) (Approximately 20 minutes)

System Requirements

Recommended Requirements	Minimum Requirements
<ul style="list-style-type: none">• Windows 10 64bit• SOLIDWORKS 2022• 12 GB of RAM	<ul style="list-style-type: none">• Windows 10 64bit• SOLIDWORKS 2015• 8 GB of RAM

Quick Start

1. Import the mesh data into SolidWorks through the Xtract3D import function.
Scan samples can be found here: [Scan Samples](#)

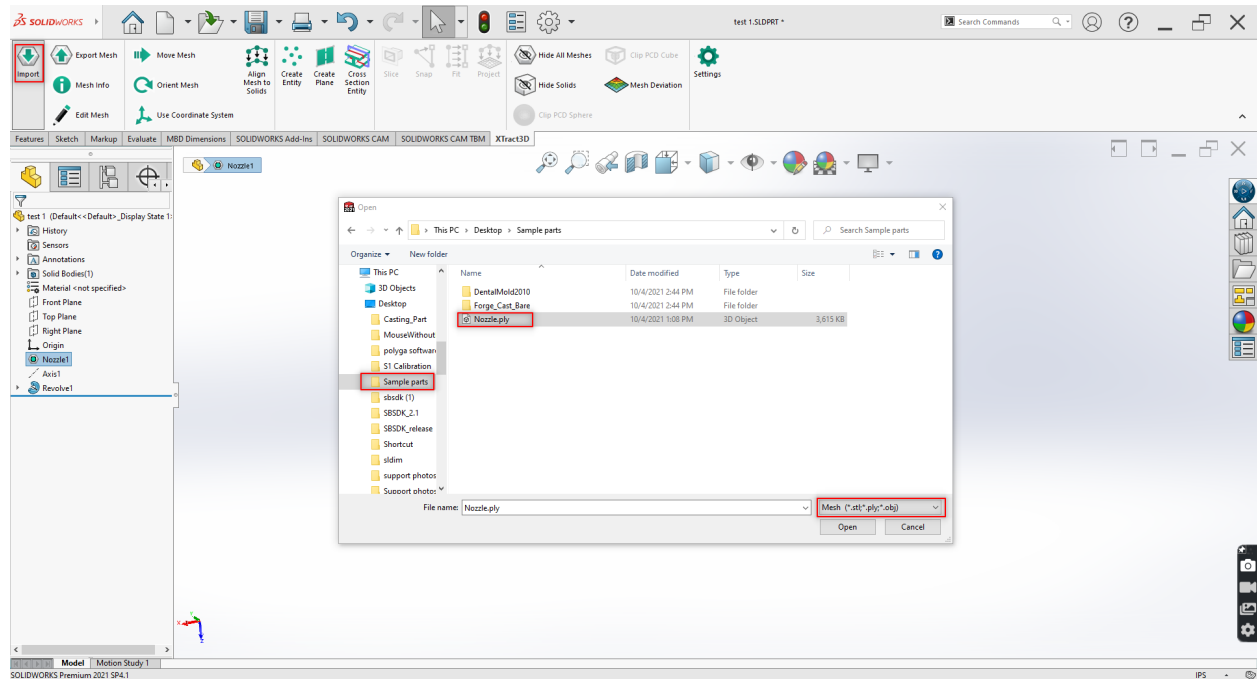

2. If the object does not align with the original coordinate system, create a new coordinate system based on the mesh data. It makes it easier to make CAD models out of the part in later steps.

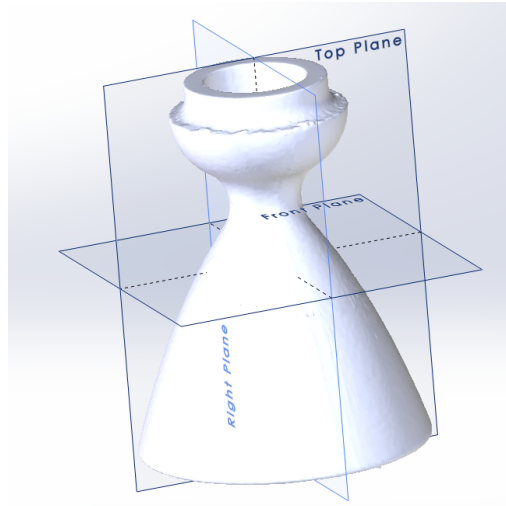

Create a new plane by using the Slice function to cut the mesh. Then the 2D cross-section of the part can be viewed.



3. Sketch the contour of the scan data outline using XTract3D and SolidWorks drafting tools.

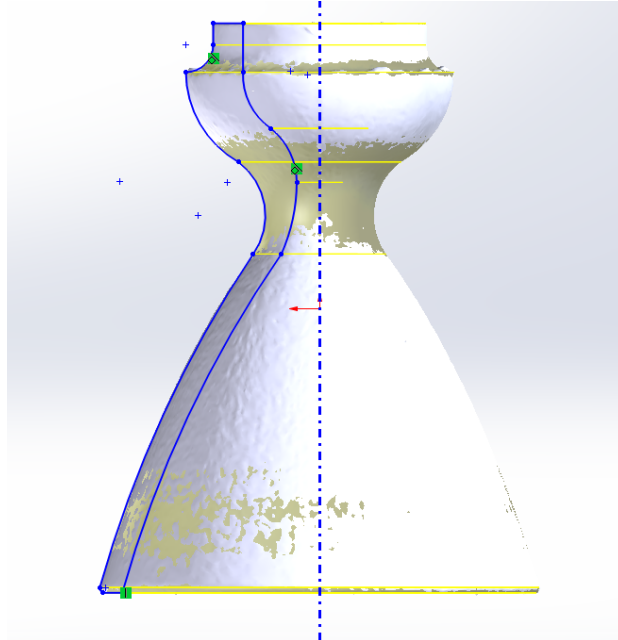

4. Revolve the sketch to get the final CAD model.

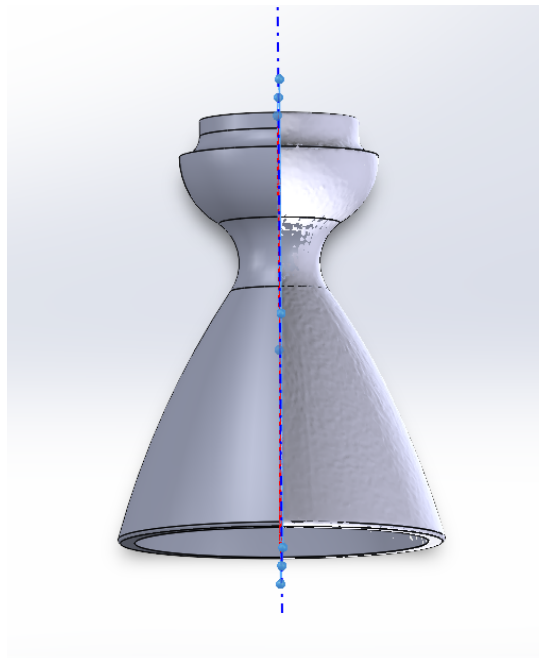

Xtract3D Fundamentals

Concepts

Xtract3D supports quickly importing high resolution Mesh and Point Cloud Data. It is a native SolidWorks add-in toolbar which allows users to perform the reverse engineering process easily within a familiar environment in SolidWorks. XTract3D focuses on providing a basic yet powerful set of tools to manually extract features, sketch, and create CAD data using the 3D scan data as a template for design.

File Import/Export



Import

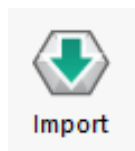

The file formats supported are shown below:

- Supported Mesh Files: .stl, .ply, .obj
- Supported Point Cloud Files: .ply, .e57, .asc, .csv, .pts, .txt, .laz, .las

Mesh Import

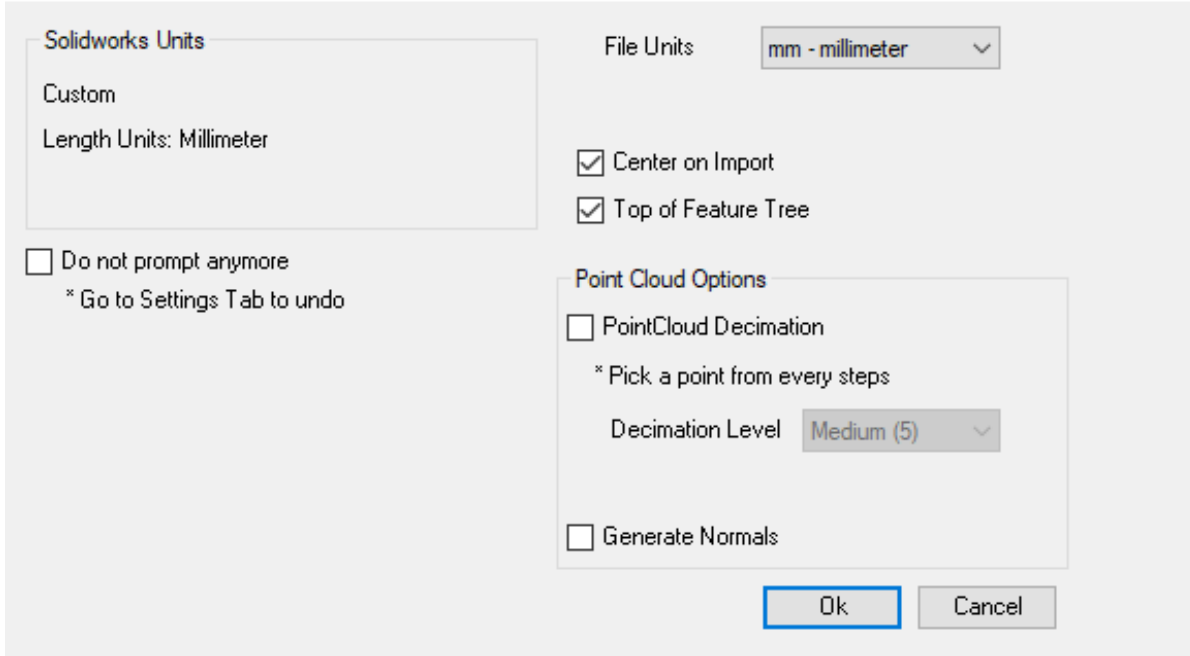

The dialog box is titled "Mesh Import" and contains the following elements:

- Solidworks Units:** A text box containing "Custom" and "Length Units: Millimeter".
- File Units:** A dropdown menu set to "mm - millimeter".
- Center on Import:** A checked checkbox.
- Top of Feature Tree:** A checked checkbox.
- Do not prompt anymore:** An unchecked checkbox with the text "* Go to Settings Tab to undo" below it.
- Point Cloud Options:** A sub-dialog box containing:
 - PointCloud Decimation:** An unchecked checkbox with the text "* Pick a point from every steps" below it.
 - Decimation Level:** A dropdown menu set to "Medium (5)".
 - Generate Normals:** An unchecked checkbox.
- Buttons:** "Ok" and "Cancel" buttons at the bottom right.

In the pop-up menu of importing mesh, users can set up correct file units and choose to place the Mesh or Point Cloud Data in the global origin. It is recommended to minimize the size of the imported data for the best rendering experience. In addition, the *Generate Normals* function will generate facing information that enables better 3d rendering of both point clouds and meshes.

Export Mesh

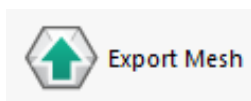

Allow users to export the current mesh data and save on the local drive.

Mesh Info

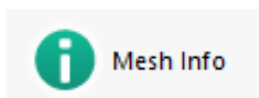

Display Mesh and Point cloud data information. Allow users to change the render settings.

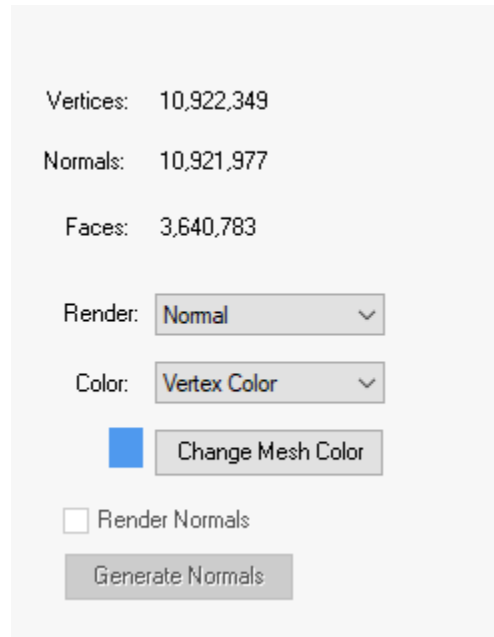

Vertices: 10,922,349
Normals: 10,921,977
Faces: 3,640,783

Render: Normal ▾
Color: Vertex Color ▾



Render Normals

Under the Mesh Info tab, users can change the render styles including Wireframe, Wiremesh and hide mesh option as well as change the color of the mesh. Users can toggle on Render Normals if the Point Cloud Data has the feature. Generate Normals allows users to generate facing information that enables better 3d rendering of both point clouds and meshes.

Edit Mesh

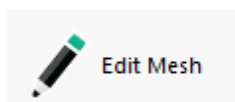

Under the Edit Mesh tab, users can edit the mesh either by deleting selected areas or by decimating. This function is only available to mesh data. Decimate Mesh allows users to decimate the original mesh data by percentage, from 10% to 99%, in terms of the values of vertices and faces.

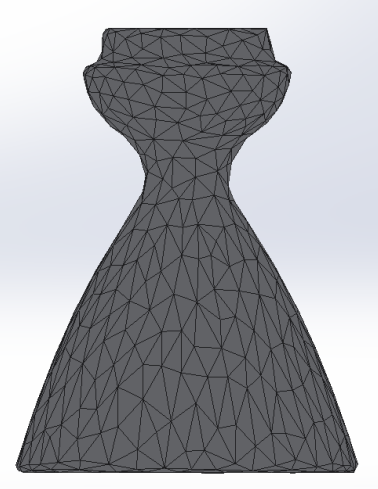
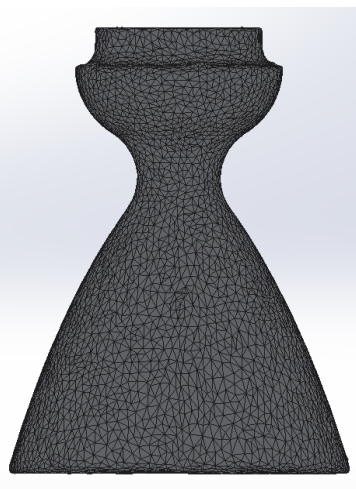
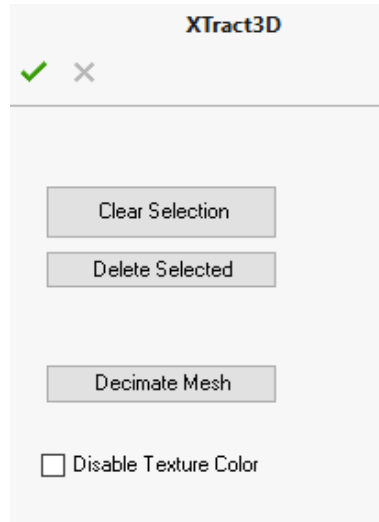

Mesh Processing

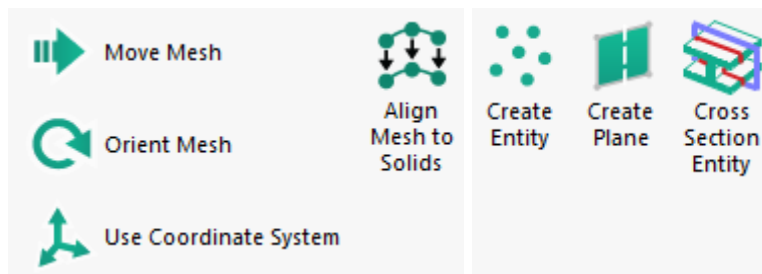

Move Mesh

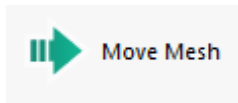

Under the Move Mesh Tab, users can translate and rotate the mesh by entering numbers into the boxes with correct units, including in, ft, um, mm, cm, m, and km. The mesh can also be reset to its origin by clicking the Auto Center Mesh button.

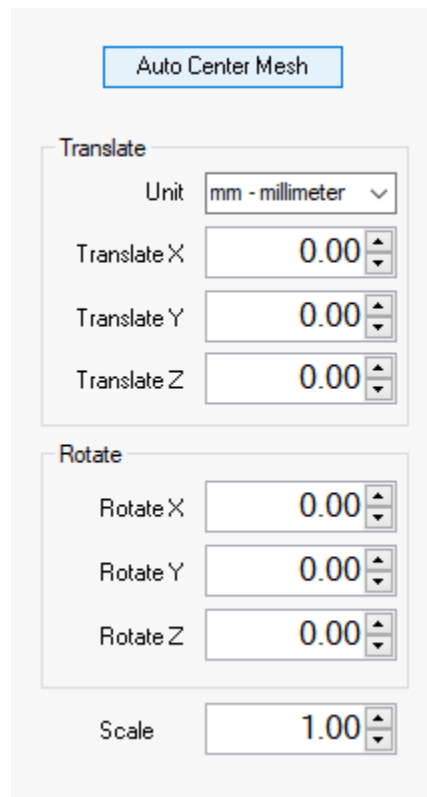

The screenshot shows a control panel for the 'Move Mesh' function. At the top is a button labeled 'Auto Center Mesh'. Below it is a 'Translate' section with a 'Unit' dropdown menu set to 'mm - millimeter'. There are three input fields for 'Translate X', 'Translate Y', and 'Translate Z', each containing the value '0.00'. Below the translate section is a 'Rotate' section with three input fields for 'Rotate X', 'Rotate Y', and 'Rotate Z', each containing the value '0.00'. At the bottom is a 'Scale' input field containing the value '1.00'. All input fields have small up and down arrow icons next to them.

Orient Mesh

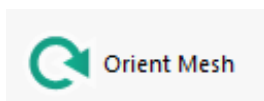

Under the Orient Mesh tab, users can change the orientation of the mesh/point cloud data by using selected points or planes.

* Rotate your selected Entity to specific reference planes.

* Choose a Plane Selection Mode

Multiple Points

Reference Plane

Clear Selected Points

* Source : None

Assign to Source Plane

* Target : None

Assign to Target Plane

Rotate Source to Target

Use Coordinate System:

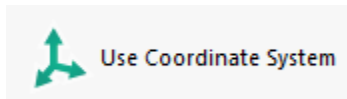

Align mesh data to the existing coordinate system. It is recommended to align the mesh position correctly into the SolidWorks coordinate system before starting the drafting and modeling process.

A detailed tutorial can be found here: [Use Coordinate System](#)

Align Mesh to Solids



Aligns Mesh data to already created Solid files. Note: The Fine Alignment option should work without having to use rough Alignment unless dealing with complex assemblies involving multiple part files or if the mesh and solid are not close to each other.



The screenshot shows a software interface with two main sections. The top section is titled "Rough Alignment Constraints" and contains instructions: "* Select 3 Points in order and Assign". It has two sub-sections: "Mesh Points" with a "Status : None" label and a "Set Three Mesh Points" button; and "Solid Points" with a "Status : None" label and a "Set Three Solid Points" button. Below these is a "Reset" button. The bottom section is titled "Alignment" and contains instructions: "* Constraints Required". It has two buttons: "Rough Alignment" and "Fine Alignment". Below the "Fine Alignment" button is a note: "* Works if the mesh is near the solids".

For Aligning mesh to Solids:

1. Click Set Three Mesh Points and select three points on the mesh surface.
2. Click Set Three Solid Points and select three points on the surface of the solid.
3. Click on Rough Alignment to roughly align both the entities.
4. Lastly, Click on Fine alignment to perfectly align the mesh to the solid.

Create Entity

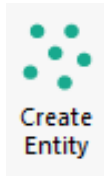

Create Entity allows users to create points, lines, splines, or centre points of a plane on Mesh. Users can toggle creating the entities on either a new sketch or a selected sketch.

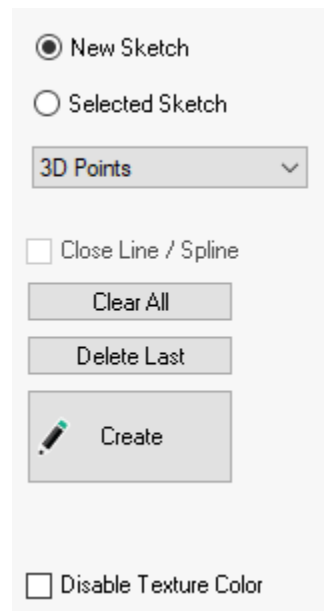
A settings panel for the 'Create Entity' tool. It contains two radio buttons: 'New Sketch' (selected) and 'Selected Sketch'. Below them is a dropdown menu currently set to '3D Points'. There is a checkbox for 'Close Line / Spline' which is unchecked. Below the checkbox are three buttons: 'Clear All', 'Delete Last', and 'Create' (which has a pencil icon). At the bottom is a checkbox for 'Disable Texture Color' which is unchecked.

Create Plane

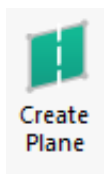

Create a plane using selected points on the mesh, surface of the mesh, splines, or from an existing plane.

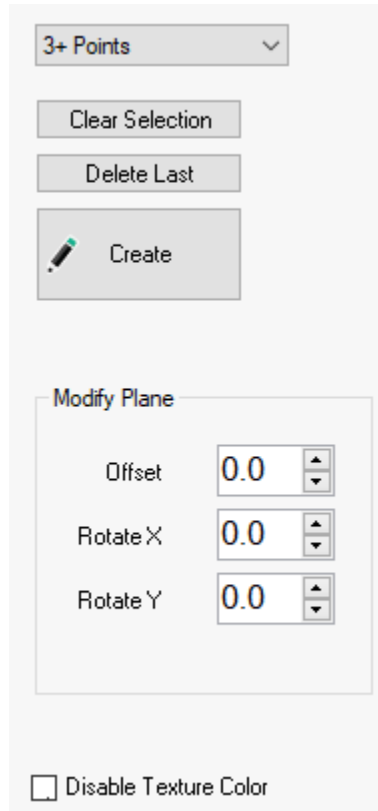

To create a plane, users can choose from the options in the dropdown menu, including 3+ points, single point, mesh select, use spline and copy plane. Users can also disable the texture color based on their preference.

Cross Section Entity

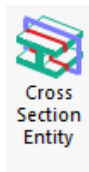

Create an intersecting plane that is perpendicular to the mesh.

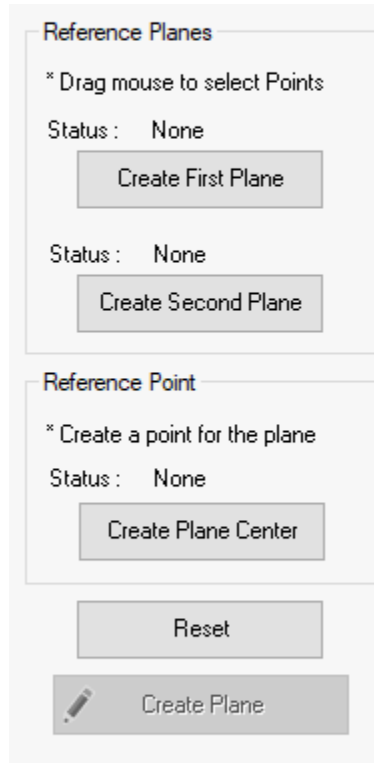

For creating an intersecting plane:

1. Click on Create First Plane and select points where the first reference plane is to be created.
2. Click on Create Second Plane and select points where the second reference plane is to be created.
3. Click on Create Plane Center and select the point where you want to place the intersecting plane.
4. Lastly, click on Create to create the plane that is perpendicular to the mesh.

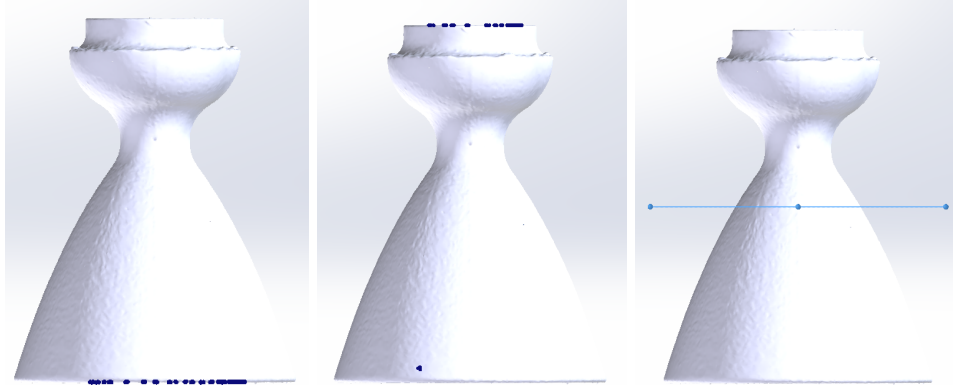

Drafting and Modeling

Slice



Cross-section slice of mesh/point cloud data at the intersection of a selected plane, face, section view, or stored slices.

A detailed tutorial can be found here: [Slice](#)

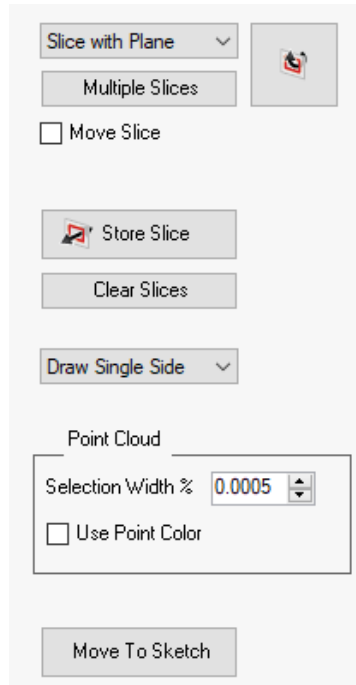

Under the Slice tab, users can choose different methods to slice the mesh. It also allows users to generate multiple linear or circular slices by setting increments and number of slices.

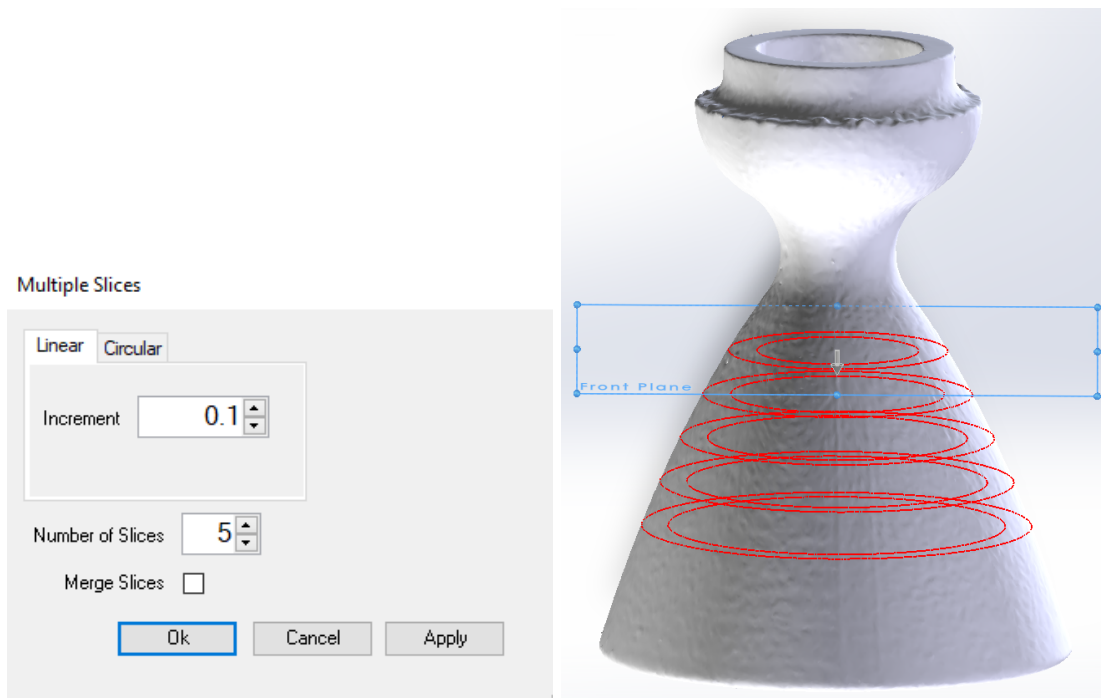

For point cloud data, users can define the width of the slice by changing Selection Width%.

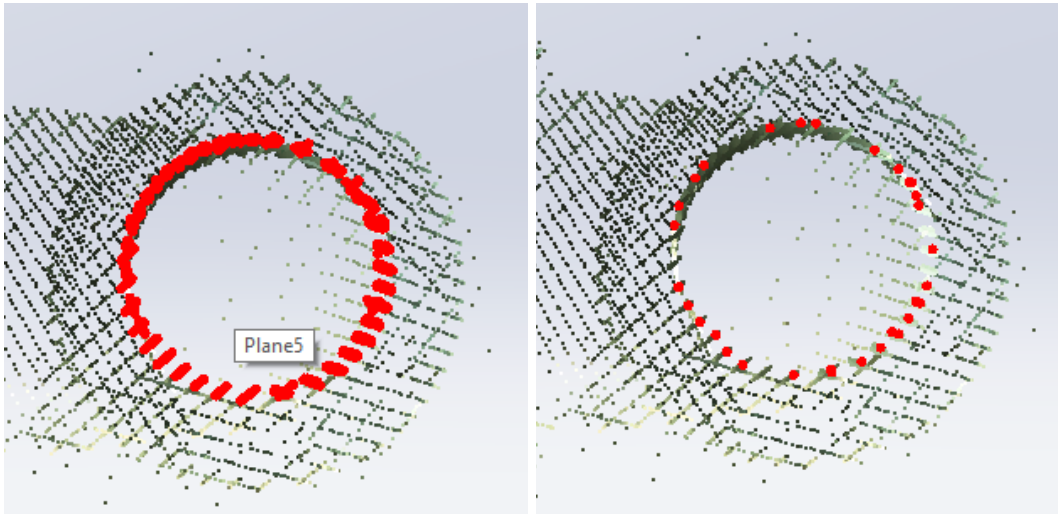

Snap

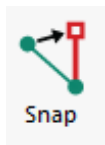

Users can snap points, lines, arcs, circles, or splines to the existing contour of the mesh data.

Fit

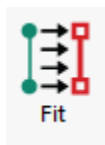

Users can fit lines, arcs, or circles to the existing contour of the mesh data after averaging it.

Fitting an arc to mesh data:

1. Sketch on the slice plane with an arc. It is acceptable to deviate from the precise model.
2. Select the arc and click *Fit*

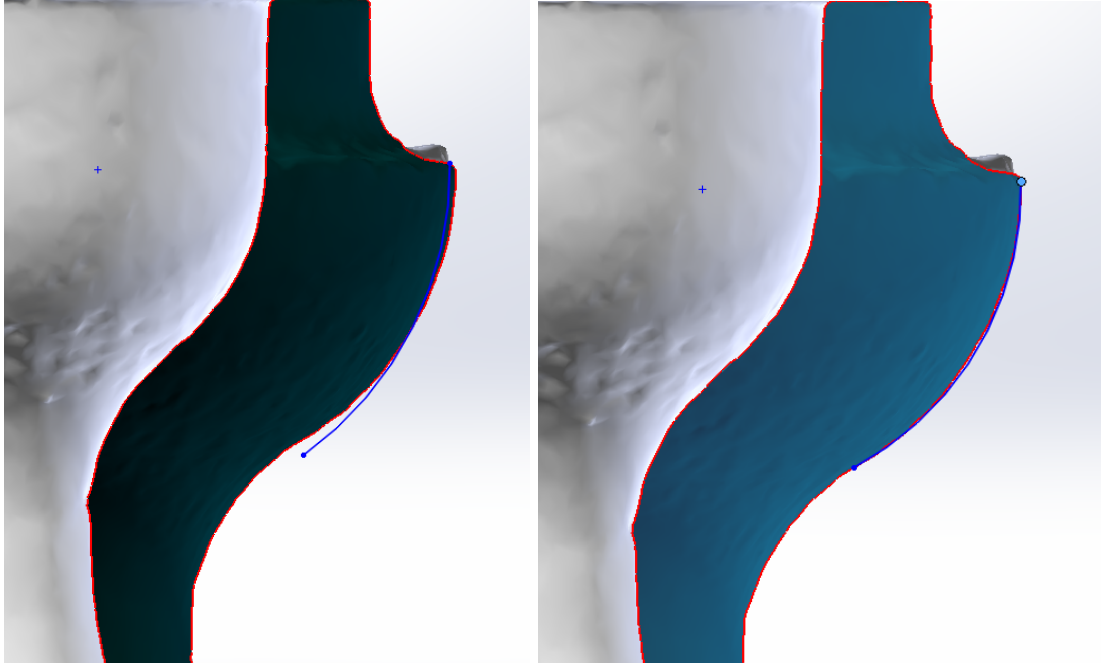

Project



Moves 3D Points, lines, or splines to the closest surface.

Point Cloud Data Processing

Hide All Meshes

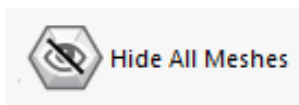

Toggle the visibility of the Mesh or Point Cloud Data.

Hide Solids

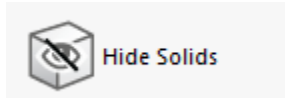

Toggle the visibility of the Solids.

Clip PCD Sphere

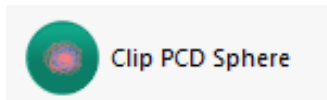

Clips the point cloud data by using a spherical tool.

Select a Point

Clip Radius:
2.0

Center Clip

Clip Volume

Reset

Delete Clipped Points

Under the Clip PCD Sphere tab, users can define a sphere by setting the radius and the center. Reset allows users to undo all the changes made so far and start over.

Clip PCD Cube



Creates a cubical shaped clipping tool for the point cloud data.

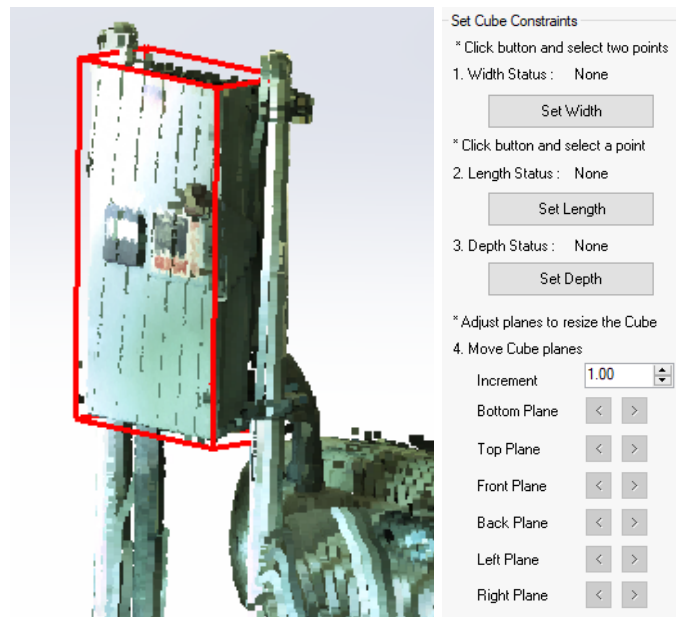

For creating a cubic clipping tool:

1. Setting Width: Click on Set Width and select two points that are far apart such that you decide the width of the cube.
2. Setting Length: Click on Set Length and select another point in the point cloud that decides the length of the cube.
3. Setting Depth: Click on Set Depth and similarly select another point that decides the width of the cube.
4. Adjust the size of the cube by incrementing or decrementing the cube planes.

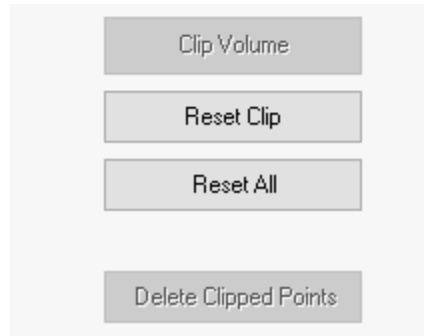

After selecting the desired size of data, users can choose to clip the point cloud data into defined shape and size by using Clip Volume, or delete the unselected data by using Delete Clipped Points (Note: Cannot revert any of the deleted points).

Mesh Deviation



Compare mesh data to CAD model and visualize the differences at different points. Users can change the color by adjusting bars on the top (CAD model color) and bars on the bottom (mesh color), to have a better understanding of the deviation.

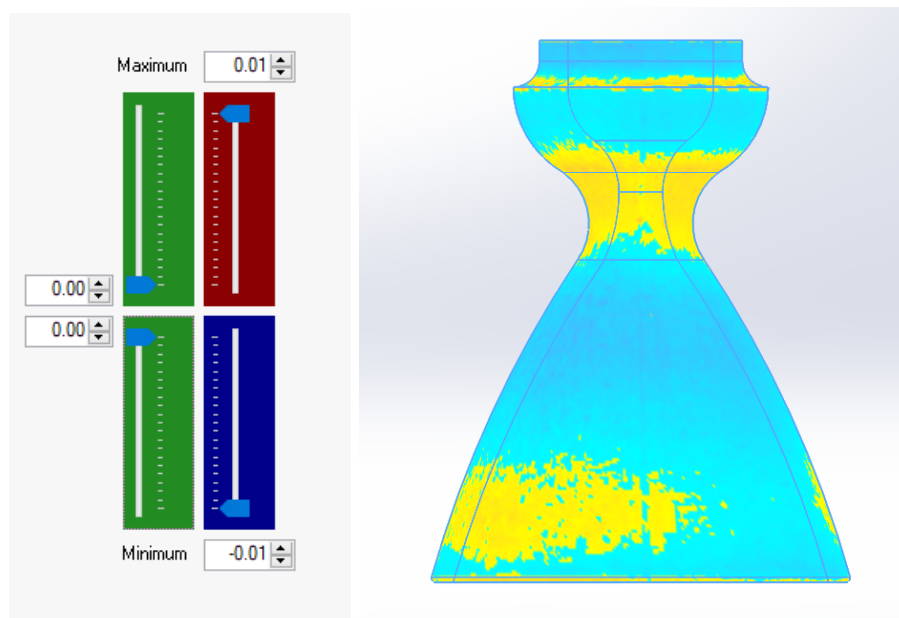

Settings

Under the Settings tab, users can find the license and Xtract3D update information, and options to export CAD as mesh and sync broken meshes. It is recommended for all users to update the Xtract3D to the latest version in order to get better performance. Details for each version can be found in Patch Notes and the latest version can be downloaded following the Check for Updates. In addition, users can change the default setting including render preference, mesh texture color and line width, point cloud data preference and import options. If there is an issue rendering mesh files that are smaller than 1 GB, users can toggle on Basic Rendering to switch back to the legacy rendering system.

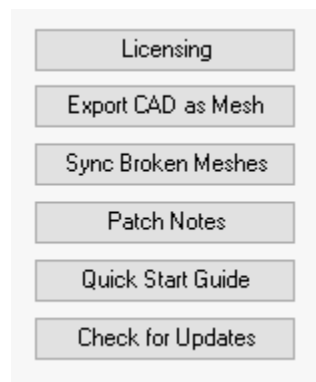

License

Normally, users are asked to fill in license information while opening the SolidWorks. If the prompt is closed, SolidWorks can still be opened without Xtract3D showing in the toolbar. Users can go to Customize (SolidWorks) -- Xtract3D and check the box. Then the license prompt will be shown again to type in license information.

The other way is to go to: C:\Program Files\Polyga\XTract3D\LicenseApp.exe and type in license information.

Users can change license information if multiple licenses are owned, by using Licensing.

Render

- Use Basic Rendering
- Fast Point Cloud Rendering

Mesh

- Line Width
- Use Mesh Texture Color
- * Only applied to Vertex Color Mesh

Point Cloud

- Selected Point Size:
- Point Size:

Import Option

- Disable Import Prompt

Advanced

- Disable auto-save on Remove